

Semi-Automatic Pallet Truck



Product performance

1. Electric hydraulic lifting and manual driving are adopted.
2. The design of pull-out guide wheel makes it easier to push and pull.
3. Lead acid battery 12V 45ah
4. Thickened profile and thickened hydraulic assembly
5. The vehicle shell is made of metal sheet metal parts.
6. Lift size is 1100MM, 1300mm, 1500MM, load 700kg.
7. The whole vehicle is mechanized and can be disassembled quickly to facilitate the replacement of parts.



Model		SE07-LB1100	SE07-LB1300	SE07-LB1500
Capacity	Q(Kg)	700	700	700
Load center	C(mm)	400	400	400
Type of lifting		电动 Electric	电动 Electric	电动 Electric
Operating type		步行 Walkie	步行 Walkie	步行 Walkie
Material		尼龙 Nylon	尼龙 Nylon	尼龙 Nylon
Wheel base	y(mm)	860	860	860
Front wheel base	b11(mm)	380	380	380
Back wheel base	b10(mm)	670	670	670
Quantity of Steering/Bearing/Balance Wheel		2/2/6	2/2/6	2/2/6
Bearing wheel size	mm	Φ70×60	Φ70×60	Φ70×60
Steering wheel size	mm	Φ100×50	Φ100×50	Φ100×50
Balance wheel size	mm	Φ40×26	Φ40×26	Φ40×26
Training wheel size	mm	Φ30×26	Φ30×26	Φ30×26
Min.fork height	mm	90	90	90
Max.fork height	h3(mm)	1100	1300	1500
Fork outside width	mm	535	535	535
Fork inside width	mm	225	225	225
Fork length	l(mm)	1160	1160	1160
Single fork size	e/s(mm)	155/60	155/60	155/60
Overall length	L1(mm)	1565	1565	1600
Overall width	b1(mm)	790	790	790
Overall height	h1(mm)	1430	1630	1830
Whole height(after tape file shelf)	h4(mm)	2680	2880	3080
Length of vertical surface to fork	l2(mm)	1160	1160	1160
Min.turning radius	Wa(mm)	1120	1120	1100
Lifting speed(laden/unladen)	mm/s	80/110	80/110	80/110
Lowering speed(laden/unladen)	mm/s	80/80	80/80	80/80
Lift motor	Kw	12V0.8	12V0.8	12V0.8
Battery capacity	V/Ah	12/45	12/45	12/45
Battery weight	Kg	10	10	10
Net weight	Kg	220	245	265

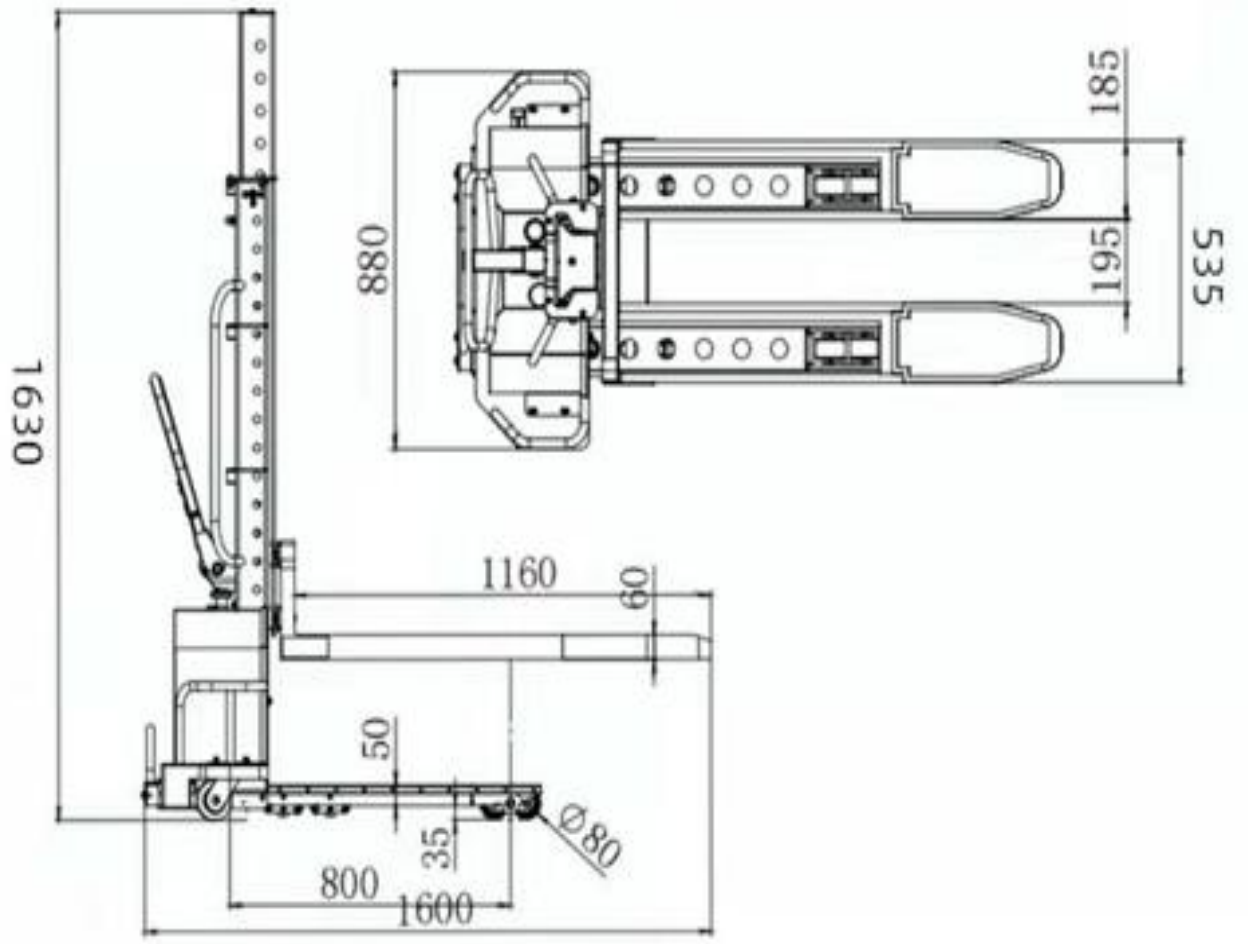

Guide Wheel Design



Support leg to increase pulling guide wheel design, pulling more easy and convenient

Yellow Balance Line



The end of the fork is marked with yellow balance line. When loading and unloading, keep the yellow balance lines in the compartment. Do not exceed the edge of the box

随车装卸货功能演示





